

ECU[®]

Voltage Detector Manual

Contents

ECU is a registered trademark of Engineering Concepts Unlimited Inc.

Copyright 2015 Engineering Concepts Unlimited Inc.

Contents

Unit review

VLD1 example

Voltage setpoint adjust

Unit Review

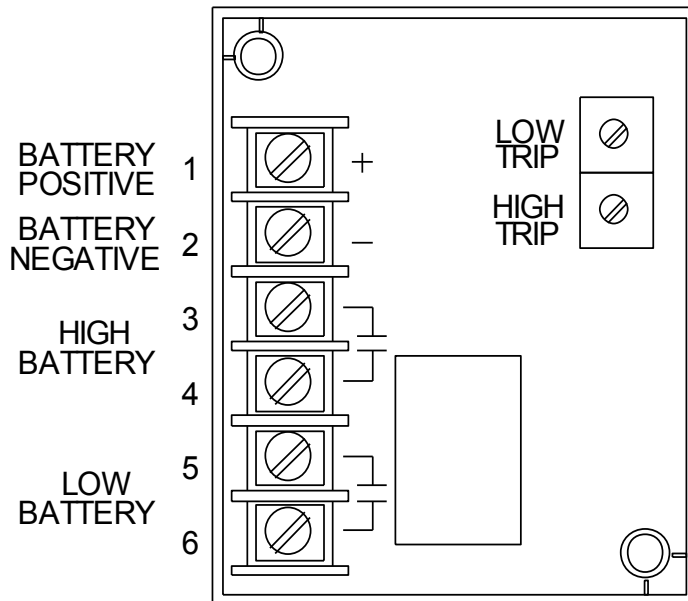

VLD2 Terminal Drawing

Output contacts
shown in de-
energized state

VLD2 shown for basic unit understanding. Refer to specific unit you are using for wiring and operation.

The VLD2 is a basic voltage detection module with built in hysteresis to prevent chatter upon reaching trip point. DC volts applied as shown will be monitored continuously and compared against the two trip points. After the unit is set it is ready for operation. The VLD1 outputs just a DC signal for a lamp load. The VLD2 outputs a relay closure allowing other types of relay loads to be applied as well as lamp loads.

Refer to the adjustments guide for more information.

VLD1 Example

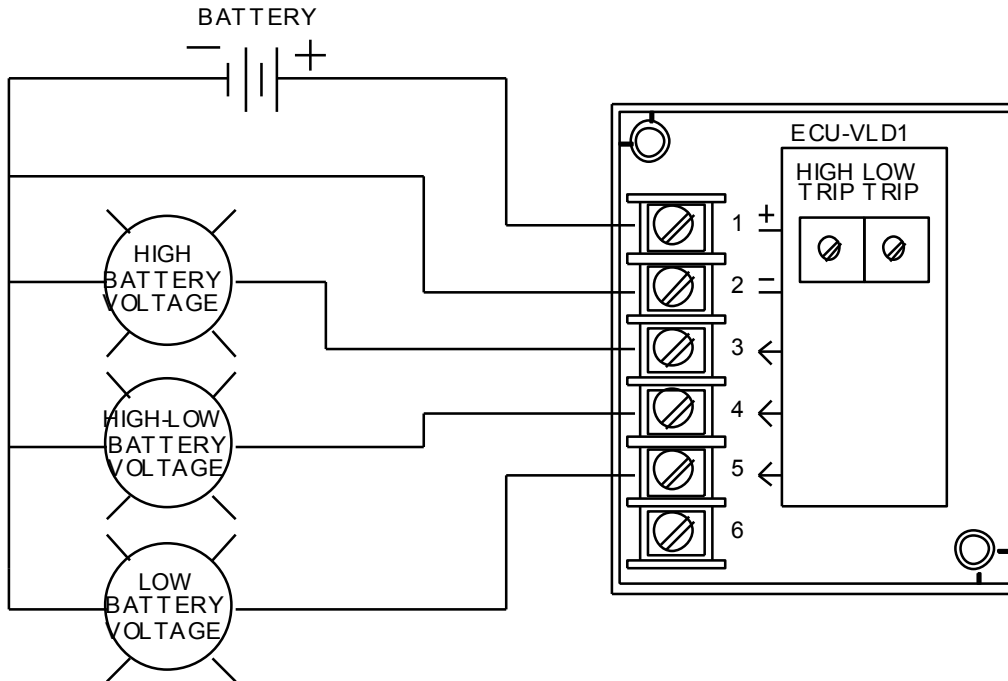

Basic VLD1 operation

The VLD1 is shown here in a typical application. The unit is monitoring the system battery and in the event it rises too high or goes too low the appropriate signal will be output to a lamp thus allowing supervisory staff to attend to the problem. The unit could have signaled a remote annunciator or other type of control device. When the voltage returns to normal the unit will deenergize the lamp output.

The only difference between the VLD1 and VLD2 is the VLD2 uses two relays to output thus it cannot have the common voltage error light. It can output larger currents than the VLD1 and is recommended for relay loads as opposed to the the VLD1.

Adjusting an **ECU®** VLD1 or VLD2

Adjusting High Voltage Trip

This adjust the high voltage trip

Turn the high pot and low pot fully counter clockwise. These pots rotate about 300 degrees of rotation. Exceeding this will damage the pots. Now connect an adjustable voltage source and set to the high setting. Slowly turn pot clockwise until high output trips. This can be checked by the lamp attached to the output turns on



Adjusting Low Voltage Trip

This adjusts low voltage trip

Remember these pots rotate about 300 degrees of rotation. Exceeding this will damage the pots. Now connect an adjustable voltage source and set to the low setting. Slowly turn pot clockwise until low output trips. This can be checked by the lamp attached to the output turns on

